



# Explorer 443s/443sp





## Fishfinder

Installation and Operation Manual

# **NORTHSTAR**★

[www.northstarnav.com](http://www.northstarnav.com)

**IMPORTANT SAFETY INFORMATION**  
**Please read carefully before installation and use.**

	This is the safety alert symbol. It is used to alert you to potential personal injury hazards, Obey all safety messages that follow this symbol to avoid possible injury or death.
	WARNING indicates a potentially hazardous situation which, if not avoided, could result in death or serious injury
	CAUTION indicates a potentially hazardous situation which, if not avoided, could result in minor or moderate injury.
	CAUTION used without the safety alert symbol indicates a potentially hazardous situation which, if not avoided, may result in property damage.

**DISCLAIMER:** It is the owner's sole responsibility to install and use the instrument and transducers in a manner that will not cause accidents, personal injury or property damage. The user of this product is solely responsible for observing safe boating practices.

BRUNSWICK NEW TECHNOLOGIES INC. AND ITS SUBSIDIARIES AND AFFILIATES DISCLAIM ALL LIABILITY FOR ANY USE OF THIS PRODUCT IN A WAY THAT MAY CAUSE ACCIDENTS, DAMAGE OR THAT MAY VIOLATE THE LAW.

Governing Language: This statement, any instruction manuals, user guides and other information relating to the product (Documentation) may be translated to, or

has been translated from, another language (Translation). In the event of any conflict between any Translation of the Documentation, the English language version of the Documentation will be the official version of the Documentation.

This manual represents the Explorer 443s/443sp as at the time of printing. Brunswick New Technologies Inc. and its subsidiaries and affiliates reserve the right to make changes to specifications without notice.

Copyright © 2006 Brunswick New Technologies Inc. Northstar™ is a registered trademark of Brunswick New Technologies Inc

### FCC Statement

Note: This equipment has been tested and found to comply with the limits for a Class B digital device, pursuant to Part 15 of the FCC Rules. These limits are designed to provide reasonable protection against harmful interference in a normal installation. This equipment generates, uses and can radiate radio frequency energy and, if not installed and used in accordance with the instructions, may cause harmful interference to radio communications. However, there is no guarantee that interference will not occur in a particular installation. If this equipment does cause harmful interference to radio or television reception, which can be determined by turning the equipment off and on, the user is encouraged to try to correct the interference by one or more of the following measures:

- Reorient or relocate the receiving antenna.
- Increase the separation between the equipment and receiver.
- Connect the equipment into an output on a circuit different from that to which the receiver is connected.
- Consult the dealer or an experienced technician for help.
- A shielded cable must be used when connecting a peripheral to the serial ports.

# Contents

---

<b>1 Introduction .....</b>	<b>5</b>
<b>2 Getting started .....</b>	<b>6</b>
2-1 Simulation Mode .....	7
<b>3 Operation .....</b>	<b>7</b>
3-1 Alarms .....	8
3-2 HISTORY screen operation .....	9
3-3 HISTORY screen interpretation .....	10
3-4 ZOOM screen .....	13
3-5 SONAR screen .....	14
3-6 NAVIGATE screen .....	15
3-7 DATA screen .....	16
3-8 RANGE menu .....	16
<b>4 SETUP menu .....</b>	<b>17</b>
4-1 ALARMS menu .....	18
4-2 UNITS menu .....	19
4-3 FISH SYMBOL .....	20
4-4 CONTRAST menu .....	20
4-5 ZOOM SPLIT .....	20
4-6 LOG menu (Explorer 443sp ONLY) .....	21
4-7 INSTALL menu .....	21
4-8 CALIBRATION menu .....	22
4-9 Resetting to Factory Defaults .....	23
<b>5 Installation .....</b>	<b>23</b>
5-1 What comes with the Explorer 443s/443sp? .....	23
5-2 Options and Accessories .....	24
5-3 Mounting the Explorer 443s/443sp Display Unit .....	24
5-4 Wiring Connection .....	25
5-5 Connecting an Explorer 443s/443sp to other instruments .....	26
<b>Appendix A - Specifications .....</b>	<b>27</b>
<b>Appendix B - Troubleshooting .....</b>	<b>28</b>

## **Important**

It is your sole responsibility to install and use Northstar's instrument & transducers in a manner that will not cause accidents, personal injury or property damage. Always observe safe boating practices. The choice, location, angle and installation of the instrument & transducers are critical to performance of the system as intended. Follow instructions in this manual carefully. If in doubt, consult your Northstar dealer.

Ensure that any holes cut are in a safe position and will not weaken the boat's structure. If in doubt, consult a qualified boat builder.

Do not install plastic through hull transducers in solid wooden hulls. Leaking through the hull may result.

Do not install bronze transducers in metal hulls. This will cause electrolytic corrosion that may result in damage to the hull or transducer.

**Sonar Performance:** The accuracy of the sonar depth display can be affected by many factors, including the type and location of the transducer and water conditions. Ensure that the transducer is located and used correctly.

**Fuel Computer:** Do not rely on the fuel computer as the sole source of information regarding available fuel onboard. Fuel economy can change drastically depending on boat loading and sea conditions. Fuel Computer information should be supplemented by visual or other checks of the fuel load. This is necessary due to possible operator errors such as forgetting to reset the fuel used when filling the tank, running the engine with the Fuel Computer not switched on, or on other operator actions that may render the device inaccurate. Always carry adequate fuel onboard for the intended trip, plus a reserve to allow for unforeseen circumstances.

**Failure to adhere to these warnings may lead to death, serious injury or property damage. Northstar disclaims all liability for installation or use of this product that causes or contributes to death, injury or property damage or that violates any law.**

As Northstar is continuously improving this product we retain the right to make changes to the product at any time which may not be reflected in this version of manual. Please contact your nearest Northstar office if you require any further assistance.

Northstar fishfinders are set up with default units of feet, °F (Fahrenheit) and knots.

Please refer to section 4-2 of this manual to change the units.

# 1 Introduction

Congratulations on choosing a Northstar fishfinder. For maximum benefit, please read this manual carefully before installation and use.

This manual describes the installation and operation procedures for the Explorer 443s/443sp.

## **The Northstar Fishfinder**

The Explorer 443s/443sp is an ultrasonic fishfinder with four levels of greyscale. It provides powerful software and a large, high-resolution screen with a zoom facility and a choice of fish symbols. As well as detecting fish, the Explorer 443s/443sp measures the water depth, battery voltage, engine hours and water temperature.

The Explorer 443sp also measures boat speed and has two distance logs (Trip Log and Total Log).

An installed Explorer 443s/443sp has two parts:

- The transducer attached to the hull.
- The display unit.

The transducer generates an ultrasonic pulse (sound that is above the hearing range of the human ear), which travels down towards the bottom, spreading out into a cone shape.

When the pulse meets an object, such as a fish or the bottom, some of the pulse is reflected back up towards the boat and is received by the transducer. The depth of an object can be calculated by measuring the time between sending the pulse and receiving its echo. The Northstar Explorer 443s/443sp will detect the bottom down to 600 feet (180 metres), depending on the clarity of the water and the type of transducer used.

The strength of an echo can vary for a number of reasons. Larger fish usually return stronger echoes, and so do fish in the middle of the cone, where the pulse is strongest. Reasons for weak echoes include the fish or object being in deep water, turbid water or in the edge of the cone where the pulse is weakest. Turbid water scatters the ultrasonic pulse and is difficult to 'see' through. Turbidity can be caused by air in the water (e.g. from another boat's wake) or by mud in the water.

## **Important**

It is vital to the performance of the fishfinder that the transducer is installed in the best location. Please follow the instructions in the Transducer Installation manual very carefully.

All of the Northstar 400 Series fishfinders use proprietary SBN Technology for sonar processing to improve signal enhancement, bottom recognition and noise rejection. SBN Technology uses the latest in digital adaptive filter algorithms to enhance all returned signals. At the same time, SBN Technology uses active noise control to reject interference, which can often be mistaken by fishfinders for true returns. Using SBN Technology, the Explorer 443s/443sp analyses the reflections from each pulse, filters false returns, and displays what is in the water under the boat.

The distinctions between the four levels of shading help the user to better interpret what is in the water and what type of bottom is under the boat.

## **Assisting with navigation**

The Explorer 443s/443sp can be used to find fish, to locate features on the bottom such as reefs or wrecks, and to help recognise favorite fishing spots from the profile of the bottom. Use the Northstar fishfinder to assist navigation by following the depth contours marked on charts.

## **CAUTION**

IMPORTANT NOTE ON USE. While any fishfinder can be used as an aid to navigation, accuracy can be influenced by many factors including the location of the transducer. It is the user's responsibility to ensure that the Explorer 443s/443sp is installed and used correctly.

## **How to find fish**

Underwater features like reefs, wrecks and rocky outcrops attract fish. Use the Explorer 443s/443sp to find these features, then look for fish by passing over the feature slowly several times using the ZOOM screen (see section 3-4). Where there is a current, the fish will often be found downstream of the feature.

For deep-sea fishing with the Explorer 443s/443sp, a rapid change in temperature may indicate the edge of a warm or cold current. The temperature difference can form a barrier, and the fish may not swim through this. Search for fish on either side of the barrier.

### **Cleaning and maintenance**

The Explorer 443s/443sp should be cleaned with a damp cloth or mild detergent. Avoid abrasive cleaners and petrol or other solvents. Always cover or remove a transom-mounted

transducer when repainting the hull. If painting over a through hull transducer with antifouling paint then use only one coat of paint. When repainting the transducer, remove previous coats of antifouling paint by sanding it lightly.

When not in use, the Explorer 443s/443sp can either be removed from the installation bracket and stored in a safe, dry, cool place such as the Northstar carry bag, or left on the installation bracket and securely covered with the optional sun cover.

## **2 Getting started**

### **Power and transducer connection**

#### **Explorer 443s**

One end of the integrated transducer/power cable has an 8 pin LT connector plug. Push this plug into the socket located on the rear of the display unit, then turn the collar to lock. Make sure that the collar is secure for a watertight connection.

#### **Explorer 443sp**

One end of the power cable has a black 8 pin LT connector plug. Push this plug into the lower socket, which has a black nut and is located on the rear of the display unit, then turn the collar to lock. Make sure that the collar is secure for a watertight connection.

One end of the transducer cable has a blue 8 pin LT connector plug. Push this plug into the upper socket, which has a blue nut and is located on the rear of the display unit, then turn the collar to lock. Make sure that the collar is secure for a watertight connection.

If the transducer is not connected, the message "NO TRANSDUCER DETECTED. ENTER SIMULATION MODE?" will appear. Press > to switch between YES, NEVER or NO. (More information on the simulation mode can be found in the following section). Press **MENU** to confirm the selection and the startup sequence will continue.

*(Note: If the transducer was not intentionally disconnected, turn the display unit off and refer to the section on Troubleshooting in Appendix B.)*

#### **Names of keys:**

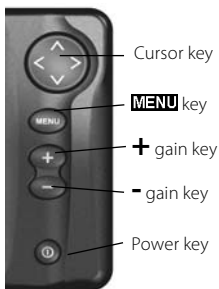

Definition of **Press** and **Hold** in this manual:

- **Press** means to push the key for less than one second.
- **Hold** means to push and hold the key down for more than one second.

#### **Power on**

To turn the fishfinder on press **⏻**.

**Note:** *if the unit is wired for Auto Power (see section 5-4) the fishfinder will turn on automatically when the boat's ignition is turned on.*

A title screen briefly appears which displays basic product information, including the software version.

The Explorer 443s/443sp then automatically displays the screen that was last used.

## Power off

To turn the fishfinder off, hold **⓪**. A countdown box appears. Continue to hold **⓪** for three seconds until the fishfinder turns off.

**Note:** If the unit is wired for Auto Power (see section 5-4) the fishfinder can only be turned off when the boat's ignition is turned off.

## Language selection

To check which language is currently selected, press **MENU** to display the MAIN MENU.

Follow these steps to change the language:

1. Power off the unit.
2. While the unit is off, hold down the **∨** key.
3. Keep holding down the **∨** key and power on the unit.

## 2-1 Simulation Mode

An internal simulator allows users to learn how to operate the fishfinder off the water.

In Simulation mode the word "SIMULATION" flashes on the bottom of the screen. The fishfinder generates data so that all the main screens appear to be operational. Any changes

4. The screen displays a list of languages. Press the Cursor **∧** or **∨** key to highlight a language, then press the Cursor **>** key to select it. The fishfinder will continue the startup sequence.

## Backlighting

Use the **⓪** button to adjust the backlighting to suit individual preferences.

Press **⓪** once, at any time, to see the backlight bar. This is displayed at the bottom of the screen and shows the current setting.

Press **⓪** repeatedly until the desired backlighting level is achieved. The backlight bar will disappear two seconds after the last press.

made to the contrast, backlighting, alarms or the display setup are saved.

To turn the Simulation mode ON or OFF, press **MENU > SETUP > highlight SIMULATE >**

## 3 Operation

### MAIN MENU screen

Northstar fishfinders are menu driven. Press **MENU** to display the MAIN MENU screen.



Press **∧** or **∨** to highlight an option, then press **>** to select it.

The MAIN MENU options are summarized below and fully explained in the following sections.

### HISTORY screen (see section 3-2)

Displays the echoes received over time, with the most recent events on the right of the screen. Use this screen when travelling to show the bottom so reefs, wrecks and fish can be found.

### ZOOM screen (see section 3-4)

This screen is split into two parts. On the right is the Full Range Section which shows part of the HISTORY Screen and to the left is the Zoom Section. Use this screen for taking a closer look at interesting underwater features.

### **SONAR screen (see section 3-5)**

Displays the strength and depth of the echoes returned from each ultrasonic pulse. The depth range is displayed in the lower right corner. This screen is a powerful aid, ideal for showing the bottom hardness and the fish species.

This screen can also be used to adjust the display shading on the HISTORY and ZOOM screens.

### **NAVIGATE screen (see section 3-6)**

Prominently displays the water depth as a digital readout. The corresponding bottom trace is also shown. These two complimentary features are particularly useful for understanding depth trends when travelling at speed.

It also displays the boat speed and the enabled alarms.

## **3-1 Alarms**

---

Alarms can be enabled to automatically detect certain conditions, such as the water being too shallow. The trigger settings for the alarms can be defined to suit the boat and individual preferences.

The fishfinder has six alarms, TOO SHALLOW, TOO DEEP, FISH ALARM, TEMP VALUE, TEMP RATE and LOW BATTERY.

The alarm symbols and beeper cycles for all of the alarms are shown in section 4-1. The FISH ALARM is three short beeps, the TOO SHALLOW ALARM is a rapid continuous beep while all others are a slower continuous beep.

When an alarm condition is met, then:

- The beeper sounds.
- The ALARMS menu is displayed on the screen with the activated alarm(s) flashing.

Press any key to acknowledge the alarm, stop the beeping and remove the ALARMS menu.

This does **not** disable the alarm. The symbol will continue to flash until the alarm condition is no longer present.

### **DATA screen (see section 3-7)**

The DATA screen displays the water temperature and water temperature history over the last 40 minutes. It also displays the boat battery voltage, log, engine-hours counter, boat speed, water depth and enabled alarms.

### **SETUP menu (see section 4)**

Use this option to customise the Explorer 443s/443sp to suit the boat and individual preferences.

### **RANGE menu (see section 3-8)**

Use this option to select either Auto or Manual Range and to change the selected depth range.

### **Alarms automatically re-enable**

The TOO SHALLOW, TOO DEEP and LOW BATTERY alarms automatically re-enable when the value moves outside the alarm trigger setting.

The TEMP VALUE alarm automatically re-enables when the temperature is more than 0.45°F (0.25°C) above or below the alarm trigger setting.

The TEMP RATE alarm automatically re-enables when the rate of temperature change falls below the trigger setting by more than 0.2°F (0.1°C) per minute.

### **Enabling Alarms and Changing Trigger Values**

See section 4-1 for information about enabling alarms and changing the trigger values.

## 3-2 HISTORY screen operation

Select MAIN MENU - HISTORY to display the HISTORY screen.

The HISTORY screen displays the most recent echoes on the right of the screen and the oldest echoes on the left. These eventually disappear off the screen.

The vertical bar on the right edge of the screen is the zoom bar. This shows the zoom range. To adjust the zoom range (see section 3-4).

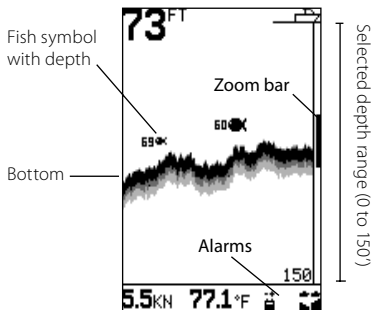

The HISTORY screen does not show a fixed distance travelled by the boat; rather, it displays what has passed below the boat during a certain period of time. The actual display depends upon the boat speed and the depth of the water.

As the boat travels through shallow water, the echoes have less distance to travel between the objects and the boat. This means that the HISTORY screen display moves across the screen more quickly than when the boat is travelling in deep water. In deep water, the echoes take longer to travel between the objects and the boat, producing a display that moves across the screen more slowly.

**Note 1:** Different fish symbols can be selected (see section 4-3).

**Note 2:** The depth of bottom can be adjusted for keel offset (see section 4-7).

### Range

Range is the depth of water displayed vertically. The Northstar fishfinder has two range modes, Auto Range and Manual Range:

- In Auto Range, the fishfinder adjusts the depth range automatically so that the bottom is always shown in the lower part of the screen. The use of Auto Range is recommended.
- In Manual Range, the fishfinder shows only a selected depth range. In areas of rapidly changing bottom depth, such as the sea floor around pinnacles, it can be useful to prevent the screen from rescaling to always show the bottom. If the bottom is deeper than the specified depth range, it will not be shown on the display screen.

To change the range mode, (see section 3-8).

### Changing the Gain Mode

Gain (sensitivity) controls the amount of detail displayed on the screen. The fishfinder has two gain modes, Auto Gain and Manual Gain:

- In Auto Gain, the gain is automatically adjusted to compensate for water depth and clarity. The use of Auto Gain is strongly recommended when learning to use a fishfinder, or when travelling at speed.
- In Manual Gain, the user can adjust the gain to compensate for water depth and clarity. Manual settings range from 1 to 9. High settings may amplify normal background noise until it appears as random pixels on the screen. The ideal setting produces only a small number of random pixels. Normally the best results with a fishfinder are obtained in Manual Gain but practice and experience are required to understand how to adjust the gain correctly.

To change between Auto Gain and Manual Gain, hold **+** or **-**. The Gain mode will be displayed briefly at the bottom of the screen.

When in Manual Gain the gain symbol  is shown at the top of the display, followed by the gain level. Press **+** to increase the gain level or press **-** to decrease the gain level.

## Fish detection and display

The fish symbol option can be customized, or switched off altogether so that the echoes are not converted to fish symbols on the screen. Section 4-4 explains how to do this. The differences between Fish symbols on and off are:

### Fish symbols ON

Using Northstar's SBN sonar technology the fishfinder analyses all return signals and eliminates most false signals and clutter so that remaining targets are most likely fish. Depending on the strength of the remaining signals, they are displayed as either small, medium or large fish

symbols with or without depth. Whilst the SBN processing is very sophisticated it is not foolproof and there will be times when the unit will not be able to differentiate between large air bubbles, rubbish containing air, fishing floats etc and genuine fish returns.

### Fish symbols OFF

For experienced users this will always provide the best information as every sonar return signal is displayed, whether it is surface clutter, a thermocline or a fish.

## 3-3 HISTORY screen interpretation

### Fish Arches

In ideal conditions and with Fish symbols turned OFF, a fish passing through the cone-shaped ultrasonic pulse is displayed on the screen as a fish arch:

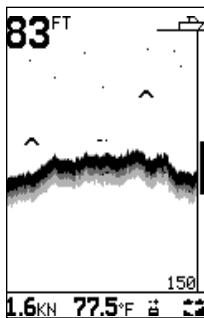

As the fish enters the weak edge of the sonar cone it generates a weak return signal that turns on the first pixel on the fishfinder screen. As the boat moves closer to the fish the distance between the transducer and the fish reduces and the return signal is displayed at progressively shallower depths, producing the start of an arch. When the fish is directly beneath the transducer and in the middle of the beam then the returned

signal is even stronger so the arch becomes thicker. As the fish passes out of the cone the reverse happens with a progressively weaker and deeper return.

In reality there are many reasons why fish arches can't be seen. For example:

- Poor transducer installation - please refer to the [Transducer Installation Guide](#).
- If the boat is anchored then fish will tend to show on the display as horizontal lines as they swim into and out of the transducer sonar beam. Slow speeds in deeper water give best fish arch returns.
- Range is important. It will be much easier to see fish arches when using Northstar's split screen zoom mode to concentrate on a particular section of water rather than just displaying everything from the surface to the bottom. Zooming increases screen resolution and is necessary for good fish arches.
- It is almost impossible to get fish arches in shallow water as the transducer sonar beam is very narrow near the surface and fish do not stay within the beam long enough to display an arch. Several fish in shallow water tend to display as randomly stacked blocks of pixels.

The following picture shows the HISTORY screen with the fish symbols turned off:

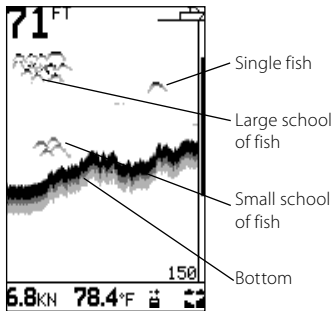

### Strength of returned echoes

The shading indicates differences in the strength of the returned echo from the bottom. A black pattern indicates a strong echo, and light grey indicates a weak echo. Fish symbols are always shown in black.

The strength of the returned echo varies with several factors, such as:

- The size of the fish, school of fish or other object.
- The depth of the fish or object.
- The location of the fish or object. The area covered by the ultrasonic beam is approximately cone-shaped and echoes are strongest in the middle.
- The clarity of water. Particles or air in the water reduce the strength of the returned echo.
- The composition or density of the object or bottom. Mud, weed and sand bottoms tend to weaken and scatter the sonar signal, which results in weaker returns. Rock or coral bottoms concentrate the return signal for strong returns.

**Note:** That planing hulls at speed produce air bubbles and turbulent water that bombard the transducer. The resulting ultrasonic noise may be picked up by the transducer and obscure the real echoes.

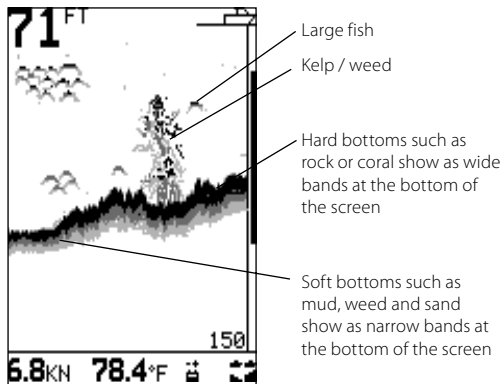

## Shadows

Shadows are areas where the ultrasonic beam cannot 'see'. These include hollows on the bottom or beside rocks and ledges where the strong echo returned off the rock obscures the weaker echo of the fish.

When looking for small objects including fish, users should consider that there are places where fishfinders cannot 'see'.

Shadow - where objects are hidden in the bottom echo.

These fish will be hidden in the bottom echo.

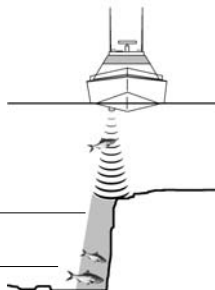

Northstar fishfinders display the most recent events on the right of the screen.

## Moving boat

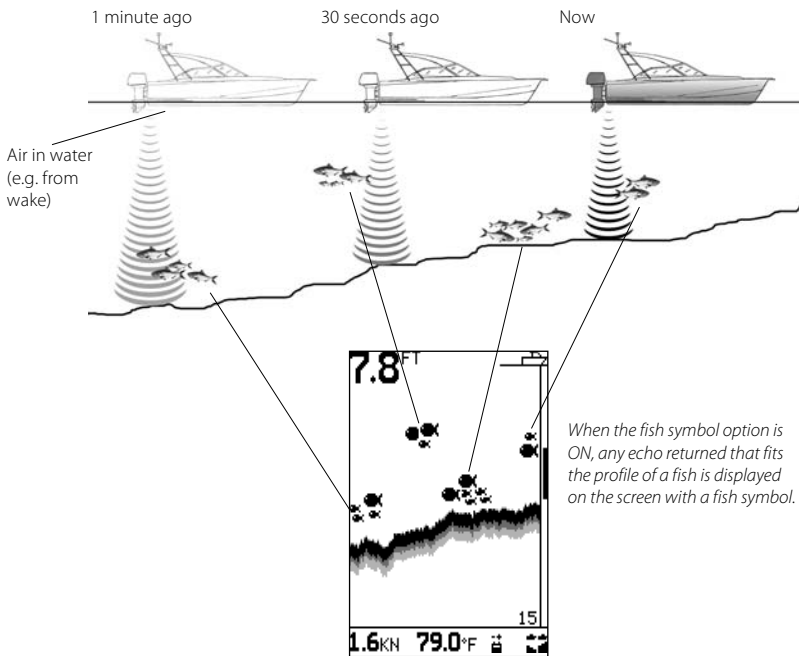

## Stationary boat

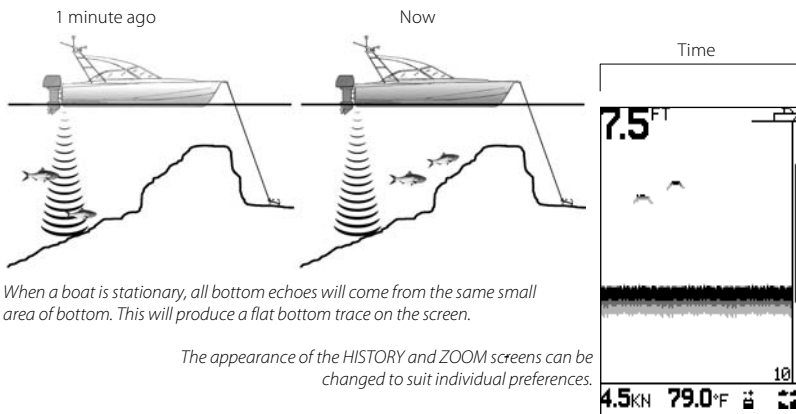

**Note:** Times indicated are for illustration only.

## 3-4 ZOOM screen

Select MAIN MENU - ZOOM to display the ZOOM screen.

The ZOOM screen is split into two parts. On the right is the full range section (just like the HISTORY screen) and on the left is the zoom section.

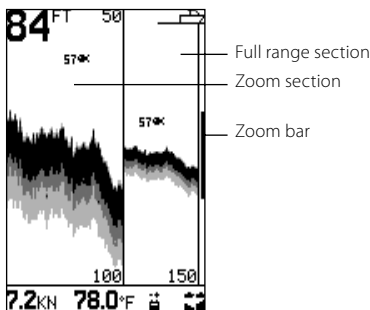

The full range section illustrated is 150 feet and the zoom bar, located on the right edge of the screen, shows the area that is enlarged in the zoom section, in this case the section between 50 ft and 100 ft.

The zoom section shows the area of interest (such as fish or features close to the bottom) in greater detail than the HISTORY screen.

### Bottom Lock

The zoom bar is normally locked to the bottom (Bottom Lock) so that the bottom is always displayed in the zoom section, regardless of changes in depth.

To turn Bottom Lock off, press  $\wedge$  then move the zoom bar to the desired position with  $\wedge$  or  $\vee$ .

To turn Bottom Lock on, move the zoom bar down until it touches the bottom and the message "BOTTOM LOCK ON" briefly appears.

If Bottom Lock is off and the bottom rises to meet the zoom bar, the zoom bar will temporarily track the bottom. This condition will cease when the depth exceeds the original depth of the zoom bar.

### Changing the Zoom

To increase magnification (make the zoom bar smaller), press  $<$ . To decrease magnification (make the zoom bar bigger), press  $>$ .

Alternatively, the zoom bar can be adjusted in the HISTORY screen before switching to ZOOM.

### 3-5 SONAR screen

Select MAIN MENU - SONAR to display the SONAR screen.

This is a powerful feature and with some experience, this screen can be used to identify both the type of bottom and the fish species.

On the Sonar Echo section on the right side, the strength of an echo at a particular depth is shown by a horizontal line at that depth. A strong echo produces a long line, whereas a weak echo produces a short line. Below the echoes the screen shows the Shading Bar. This disappears from view after a few seconds, but just press < to re-display it.

The left side of the screen is the Fish History section. Using the Shading Bar as a control, the fishfinder interprets the echoes shown on the Sonar Echo section and uses this information to draw the Fish History section.

#### Recognising the Type of Bottom

The bottom trace is the strongest echo shown in the lower part of the left side of the screen.

A bottom trace with a wide black layer is indicative of a hard bottom, because a hard bottom returns strong echoes. Conversely, a soft bottom produces medium or weak echoes, which are shown by a narrower trace.

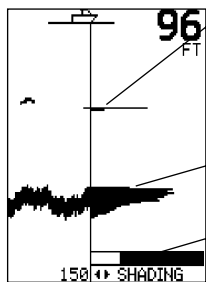

*Small strong echo (e.g. fish). This usually flashes on and off as the ultrasonic pulse strikes the fish.*

*Large strong signal (e.g. bottom)*

*Shading Bar*

#### Recognising the Type of Fish

Different species of fish have different sizes and shapes of swim bladders. The air in the swim bladder reflects the ultrasonic pulse, so the strength of the echo varies between fish species according to the size and shape of the swim bladder. The sonar display is 70 pixels wide, so it can show 70 levels of return echo strength, which is a powerful feature.

When fishing among a school of fish and catching them, note the fish species and the strength of the echo that it returns on the fishfinder on the Sonar Echo screen. Then, the next time that particular return on the fishfinder is seen, it is likely to be the same fish species.

#### Adjusting the Shading Bar

The Shading Bar is displayed as a horizontal bar in the lower half of the screen. Adjust the Shading Bar so different strength echoes have a different shade on the screen. Weaker echoes can be shown as light grey, and the strongest echoes shown as black.

Increase the black part of the Shading Bar by pressing < if there are too few long (strong) echoes being displayed in black.

Decrease the black part of the Shading Bar by pressing > if there are too many long (strong) echoes being displayed.

## Manual Gain

When Manual Gain is selected, increasing the gain setting will result in more detail being shown on the fishfinder display. Decreasing the gain will reduce detail being shown. See 'Changing the Gain Mode' in section 3-2 for more information on changing Gain settings.

Gain setting

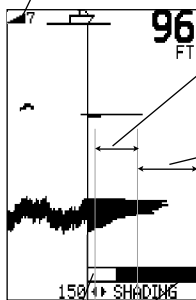

These echoes will be shown in grey on the Fish History section.

These strong echoes will be shown in black on the Fish History section.

The weak echoes within this white section of the shading bar will not be shown - they are below the threshold of where the shading begins.

Increasing Gain by pressing + will move the edge of the light grey bar to the left and result in weaker echoes being displayed in the Fish History section. Pressing - will move the edge of the grey bar to the right.

## 3-6 NAVIGATE screen

Select MAIN MENU - NAVIGATE to display the NAVIGATE screen.

The NAVIGATE screen displays useful information while travelling at speed. It prominently displays the water depth, the boat speed, the bottom profile and any alarms that are enabled.

**Depth** can be displayed in feet (FT), fathoms (FA), or metres (M). Use the SETUP - UNITS - DEPTH

menu to select the required depth units (see section 4-2).

**Speed (443sp ONLY)** can be displayed in knots (KN), miles per hour (MPH), or kilometres per hour (KPH). Use the SETUP - UNITS - SPEED menu to select the desired speed units (see section 4-2).

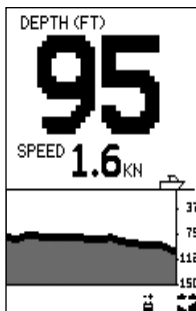

**TIP:** Use the < key to immediately return to the fish finder screens.

### 3-7 DATA screen

Select MAIN MENU - DATA to display the DATA screen:

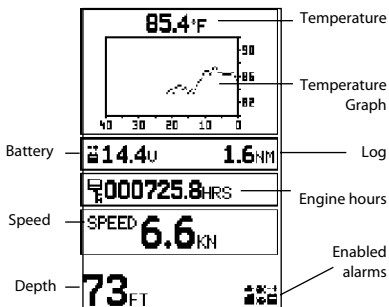

A graph displays the surface water temperature for the last 40 minutes and is updated every 30 seconds. The current water temperature is displayed above the graph and is updated every second.

**TIP:** Use the < key to immediately return to the fish finder screens.

### 3-8 RANGE menu

Select MAIN MENU - RANGE to change the manual range and adjust the selected depth range.

The range setup box is displayed. This shows the depth of water displayed vertically and the range mode setting.

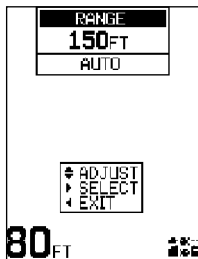

The temperature can be displayed in °F (Fahrenheit) or °C (Celsius). Use the SETUP - UNITS - TEMPERATURE menu to select the desired temperature units (see section 4-2).

Alarms that indicate a specific temperature, or rate of change of temperature, may be enabled (see section 4-1).

**Log (443sp ONLY)** One of two distance logs can be displayed: Trip Log or Total Log. Both logs are retained in the Explorer 443s/443sp memory when the unit is switched off.

Use the SETUP - LOG menu to select the Trip Log or Total Log (see section 4-6). The Trip Log must be reset manually (e.g. to record total mileage during a season, or the distance travelled on this trip).

**Note:** That the units displayed on each Log will correspond with the Speed.

**Speed (443sp ONLY)** can be displayed in knots (KN), miles per hour (MPH), or kilometres per hour (KPH). Use the SETUP - UNITS - SPEED menu to select the desired speed units (see section 4-2).

Northstar fishfinders has two range modes, Auto Range and Manual Range. The use of Auto Range is recommended. See section 3-2 for more details.

To change between Auto Range and Manual Range, press >.

The Manual Range mode offers the user a choice of pre-selected water depths. Use ^ and v to display the options and select a water depth.

Press < to exit.

## 4 SETUP menu

Select MAIN MENU - SETUP to display the SETUP menu:



Use the SETUP menu to customize settings to suit the boat and individual preferences, as follows:

- Specify the trigger settings for the alarms (see section 4-1).
- Choose the units for depth, temperature, speed and fuel (see section 4-2).
- Turn the key beep on or off.
- Choose the fish symbol (see section 4-3).
- Choose the contrast level (see section 4-4).
- Turn Simulation mode on or off
- Turn Zoom Split on or off (see section 4-5)
- Select the Trip Log or the Total Log (see section 4-6).
- Zero Trip Log or zero all logs (see section 4-6).
- Select language, setup the keel offset (see section 4-7).
- Calibrate speed and temperature sensors (see section 4-7).

Press  $\wedge$  or  $\vee$  to highlight an option, then see the following sections.

## 4-1 ALARMS menu

Select MAIN MENU - SETUP - ALARMS to display the available alarms. Press  $\wedge$  or  $\vee$  to highlight an option.









Alarms can be enabled to automatically detect certain conditions, such as the water being too shallow. Trigger settings can be defined to suit the boat and individual preferences.

When an alarm condition is met, then:

- The beeper sounds.
- The ALARMS menu is displayed on the screen with the activated alarm symbol(s) flashing.

Press any key to acknowledge the alarm, stop the beeping and remove the ALARMS menu. This does not disable the alarm. The symbol will continue to flash until the alarm condition is no longer present.

The beeper cycle is different for some alarms. All of the alarm symbols and beeper cycles are shown:

Symbol	Alarm Name	Beeper Cycle	Alarm condition is met when:
	Temp Value	$\frac{1}{2}$ sec	the temperature equals the alarm trigger value
	Temp Rate	$\frac{1}{2}$ sec	the rate of change of temperature equals the alarm trigger value
	Too Shallow	$\frac{1}{5}$ sec	the depth is less than the alarm trigger value
	Too Deep	$\frac{1}{2}$ sec	the depth is greater than the alarm trigger value
	Fish Alarm	3 short beeps	an echo matches the profile of a fish
	Low Battery	$\frac{1}{2}$ sec	the battery voltage is less than the alarm trigger value

**Note:** The FISH ALARM gives only three short beeps.

### Alarms automatically re-enable

The TOO SHALLOW, TOO DEEP and LOW BATTERY alarms automatically re-enable when the value moves outside the alarm trigger setting.

The TEMP VALUE alarm automatically re-enables when the temperature is more than 0.45°F (0.25°C) above or below the alarm trigger setting.

The TEMP RATE alarm automatically re-enables when the rate of temperature change falls below the trigger setting by more than 0.2°F (0.1°C) per minute.

## Flashing Light and/or External Beeper

If a secondary alarm indicator is required, a flashing light and/or external beeper can be installed. These can be positioned anywhere suitable on the boat. For installation advice see section 5-4.

## Enabling Alarms and Changing Trigger Values

Press  $\wedge$  or  $\vee$  to highlight an alarm, then press  $\>$  to select it. To enable or disable an Alarm, press  $\>$  to switch between ON and OFF.

To set the trigger value for an Alarm, press  $\wedge$  or  $\vee$  to increase or decrease the trigger value.

The alarm trigger value is retained even when the alarm is disabled.

## 4-2 UNITS menu

Select MAIN MENU - SETUP - UNITS to define the units for depth, temperature, speed and fuel.

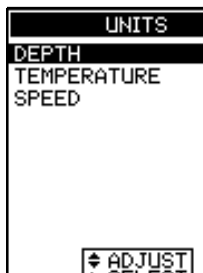

Press  $\wedge$  or  $\vee$  to highlight an option.

### DEPTH

Can be displayed in units of feet (FT), fathoms (FA), or metres (M). Press  $\>$  to select the required depth units.

### TEMPERATURE

Can be displayed in °F (Fahrenheit) or °C (Celsius). Press  $\>$  to select the required temperature units.

### SPEED

Can be displayed in knots (KN), miles per hour (MPH), or kilometres per hour (KPH). Press  $\>$  to select the required speed units.

**Note:** Distance units will change automatically to match the speed units.

### 4-3 FISH SYMBOL

Select MAIN MENU - SETUP - FISH SYMBOL to display the fish symbol options for the screen displays.

There are three options. Press > to select:



- OFF
- 
- 

OFF

Displays echoes as dots on the screen.



Displays any echoes returned that match the profile of a fish as a fish symbol in one of three sizes:

-  Strongest echo
-  Average echo
-  Weakest echo

Echoes which are not recognised as fish are displayed as dots on the screen.



Displays any echoes returned that match the profile of a fish as a fish symbol in one of three sizes as above. The depth of the fish is shown to the left of the symbol. Echoes which are not recognised as fish are displayed as dots on the screen.

Use the FISH FILTER setting to adjust the fish detection. (see section 4-9)

### 4-4 CONTRAST menu

Select MAIN MENU - SETUP - CONTRAST to display the contrast setting box and the current setting.

The contrast level can be set at any level between 0 and 16. The default setting is 6.

Press ^ or v to increase or decrease the setting to the required level. Then press < to exit.

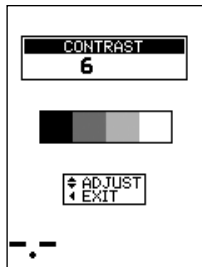

### 4-5 ZOOM SPLIT

Select OFF to obtain a zoom only screen. (full screen zoom)

Select ON to obtain a split zoom / history screen (default)

## 4-6 LOG menu (Explorer 443sp ONLY)

Select MAIN MENU - SETUP - LOG to display the available options.

Press  $\wedge$  or  $\vee$  to highlight an option:

### LOG

Selects which log is displayed on the DATA screen, TOTAL or TRIP.

Press  $\>$  to choose between TRIP or TOTAL. Both logs are retained in the Northstar fishfinder but only the selected log is displayed.

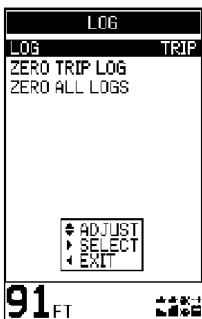

### ZERO TRIP LOG

Resetting the trip log will return the trip log value to zero. The trip log is retained in the fishfinder memory so it retains the distance value if the fishfinder is switched off during a trip. Therefore, the trip log needs to be reset manually each time the user wishes to log a trip.

Press  $\wedge$  or  $\vee$  to highlight ZERO TRIP LOG, then press  $\>$  to select it. The message box "ZERO TRIP LOG YES" appears.

Press  $\>$  to select YES or NO. Then press **MENU** or  $\leftarrow$  to reset the trip log and exit.

### ZERO ALL LOGS

Resetting both logs will return both the trip log and the total log values to zero.

Press  $\wedge$  or  $\vee$  to highlight ZERO ALL LOGS, then press  $\>$  to select it. The message box "ZERO ALL LOGS YES" appears.

Press  $\>$  to select YES or NO. Then press **MENU** or  $\leftarrow$  to exit.

## 4-7 INSTALL menu

Use this menu at installation time, to select the language and to enter the keel offset value, the number of engines and the fuel tank size. The INSTALL menu can also be used to calibrate the water temperature and boat speed.

Select MAIN MENU - SETUP - INSTALL to display the menu.



Press  $\wedge$  or  $\vee$  to highlight an option.

### LANGUAGE

The following languages are available: English, French, German, Spanish, Italian, Dutch, Swedish, Portuguese, Finnish and Greek.

Press  $\wedge$  or  $\vee$  to highlight the selected language, then press **MENU** to save and exit.

### KEEL OFFSET

Keel offset is the distance between the location of the depth transducer and the point the displayed depth is measured from.

Enter a keel offset value when the transducer is located below the water surface but a display of total water depth is required, or when the depth of water below the boat's keel is required.

Press  $\wedge$  or  $\vee$  to select KEEL OFFSET, then press  $\>$  to display the keel offset box.

Negative values display the depth as measured from a point below the transducer (e.g. keel). Positive values display the depth as measured from a point above the transducer (e.g. water surface).

Press  $\wedge$  or  $\vee$  to increase or decrease the value.

Use *Keel Offset* either when the transducer is located below the water surface but a display of total water depth is required, or when depth of water below the boat's keel is required.

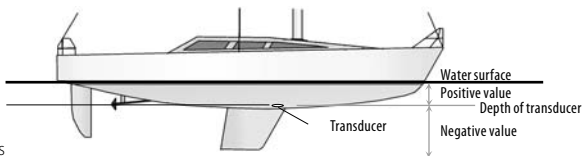

**Note:** Boat illustrated uses a through hull transducer

Enter **positive** values to display depth as measured from a point **above** the transducer (e.g. water surface).

Enter **negative** values to display depth as measured from a point **below** the transducer (e.g. keel).

## 4-8 CALIBRATION menu

Use this menu to calibrate water temperature, boat speed, fuel readings and the fuel flow filter.

Select MAIN MENU - SETUP - INSTALL - CALIBRATION to display the calibration menu.

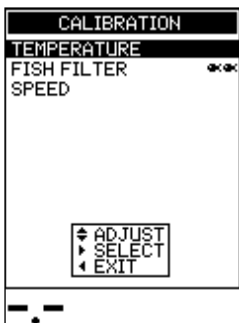

### Calibrating the Temperature

The factory settings should be sufficiently accurate for normal usage. However, to calibrate the temperature readout, first measure the water temperature.

Then, to calibrate the setting, select TEMPERATURE then press > to display the temperature readout box. Press ^ or v to increase or decrease the value to match the measured temperature.

(To change the temperature units between °F (Fahrenheit) or °C (Celsius), use the SETUP - UNITS menu (see section 4-2).

### Calibrating the Fish Filter

Use this to adjust the fish detection when FISH SYMBOLS are switched on. Fish detection depends on water clarity, fish species and fish size. Calibration may be required if too little or too much fish are being detected. Select more fish symbols to increase the number of detected fish. Select less fish symbols to reduce the fish detection.

### Calibrating the Speed (443sp ONLY)

Use this to calibrate the boat's speed and log. Calibration may be required because different hull shapes have different flow characteristics.

Obtain an accurate measurement of the boat's speed from a GPS receiver; by following another boat traveling at a known speed; or by making a timed run over a known distance.

**Note:** that for accurate calibration:

- The speed from a GPS receiver should be greater than 5 knots.
- The speed from another paddlewheel transducer should be between 5 and 20 knots.
- Best results are achieved in calm conditions where there is minimal current (best at high or low tide).

Use ^ or v to highlight the SPEED option, then press > to display the speed readout box. Press ^ or v to increase or decrease the readout to match the independent speed value.

## 4-9 Resetting to Factory Defaults

### Important:

This option resets all of the following settings and resets them to the manufacturer's default settings.

Speed and distance are related. For example, if knots are chosen as the speed units, then distance is always measured in nautical miles.

To reset the fishfinder to the manufacturer's default settings, power off the fishfinder. Then hold < and power on while holding it.

The message "RESET TO FACTORY DEFAULTS?" appears. Press > to select YES or NO. Then press **MENU** or < to reset the trip log and exit.

### GENERAL

Auto Gain .....	ON
Auto Range .....	ON
Manual Gain .....	5
Bottom Lock .....	ON
Key Beep .....	ON
Contrast .....	6
Backlighting .....	10

### UNITS

Temperature .....	°F
Depth .....	Feet
Speed .....	KN

### ALARMS

Shallow Alarm .....	OFF
Shallow Alarm Value .....	10 ft
Deep Alarm .....	OFF
Deep Alarm Value .....	60 ft
Fish Alarm .....	OFF
Temp. Change Alarm .....	OFF
Temp. Change Alarm Value .....	5.0 °F
Temp. Alarm .....	OFF
Temp. Alarm Value .....	80 °F
Low Battery Alarm .....	OFF
Battery Alarm Value .....	11.5 Volts
FISH SYMBOL .....	<b>26</b>

### INSTALL

Keel Offset .....	0.0 ft
Fish Filter .....	<b>OFF</b>

## 5 Installation

Correct installation is critical to the performance of the Explorer 443s/443sp. There are two components to install, the display unit and the transducer. It is vital to read the entire installation

section of this manual and the documentation that comes with the transducer before attempting installation.

### 5-1 What comes with the Explorer 443s/443sp?

Standard configuration

- Explorer 443s/443sp display unit.
- Power cable.
- Mounting bracket (screws included).
- Warranty registration card.
- This manual.
- Transducer (includes cable kit and screws).
- Transducer Installation Manual.
- Screws.



## 5-2 Options and Accessories

---

### Optional transducers

- Through hull Speed/Temperature transducer.
- Through hull Depth transducer.
- In hull Depth transducer.

### Other options and accessories

- Replacement paddle wheel.
- Adapter cable for through hull transducer.
- Carry bag.
- Transducer extension cable.
- Sun cover.

### Depth Repeater

Repeater for Depth, Speed, Water Temperature, Battery Voltage (see section 5-5).

Please consult your Northstar dealer for more information.

## 5-3 Mounting the Explorer 443s/443sp Display Unit

---

There are two mounting arrangements:

- **Flush mounting** requires a solid panel with access behind for wiring and mounting screws.
- **Bracket mounting** requires a panel for mounting the bracket. The bracket can be rotated and tilted.

Select a position where the display head will be:

- At least 4" (100 mm) away from the compass.
- At least 12" (300 mm) away from any radio transmitter.
- At least 4' (1.2 m) away from any antenna.
- Easy to read by the helmsman and crew while underway.
- Protected from physical damage during rough sea passages.
- Easy to access the 12 volt power source.
- Convenient to route the transducer cables.

### Bracket mounting

1. Fix the mounting bracket onto the boat using the three stainless steel screws. Do not overtighten as the bracket may not rotate.
2. Push the display unit onto the mounting bracket and tighten it firmly using the knob on the mounting bracket.
3. Attach the cables.

### Removing the Explorer 443s/443sp

The Explorer 443s/443sp can be removed after each use for protection against the environment or security reasons.

When removing the Explorer 443s/443sp ensure that the plugs left in the boat are not exposed to the elements. Push the attached dust covers over the exposed ends of the plugs. Keep the display unit in a dry clean place such as the optional Northstar carry bag.

### Flush mounting

1. Cut a hole in the bulkhead for the display unit using the flush mount template.
2. Drill four holes for the mounting studs using the flush mount template.
3. Screw the four studs into the brass inserts in the back of the display unit.
4. Sit the display unit in place and fit the washers and nuts to the studs.

## 5-4 Wiring Connection

### CAUTION

1 Amp fuses must be positioned where shown in the wiring diagrams.

If possible, route the transducer cables away from other wiring on the boat. Electrical noise from engine wiring, bilge pumps and other electrical equipment can affect the unit.

The shortest and most direct connection to the boat's battery helps to minimise voltage drop. Ensure that any cable connections do not lay in the bilge.

Two wiring options are described in this section:

- **Basic Wiring.** This does not start the fishfinder automatically when the boat ignition is switched on and it disables the engine hours counter.
- **Auto Power Wiring.** This must be used for engine hours and fuel computer options.

### CAUTION

The Explorer 443s/443sp **must** be run off a 12 volt battery and **must not** be run off a circuit without a battery.

#### Basic Wiring

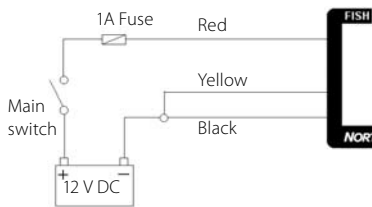

**Black wire:** Connect this to the negative battery terminal.

**Red wire:** Connect this to the 12 V positive battery terminal after the main switch. Fit a 1 Amp fuse as shown.

**Yellow wire:** Connect this to the black wire. This disables the engine hours counter.

Power on the fishfinder manually whenever the main switch is on.

#### Auto Power Wiring

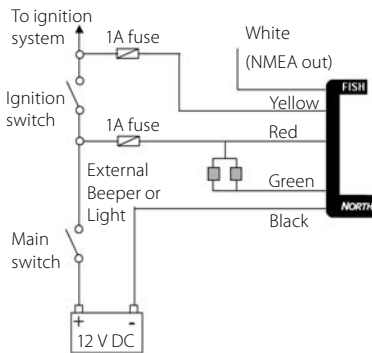

**Black wire:** Connect this to the negative battery terminal.

**Red wire:** Connect this to the 12 V positive battery terminal after the main switch. Fit a 1 Amp fuse as shown.

**Yellow wire:** To enable the engine hours counter and start the fishfinder automatically when the ignition is turned on, connect the yellow wire to the ignition system, through a 1 Amp fuse.

**Note:** That the fishfinder cannot be turned off while the ignition is on.

#### Flashing Light and/or External beeper (443sp ONLY)

Use the green wire, if desired, to connect a secondary alarm indicator such as a flashing light or a 12 V external beeper with a built in drive circuit. Refer to the wiring diagram. If the external beeper or light requires more than 250 mA DC total, fit a 12 V relay. Consult your Northstar dealer for more advice.

#### NMEA Instruments (443sp ONLY)

Use the white wire, if desired, to connect the fishfinder to other NMEA instruments such as Northstar's depth repeater. (See section 5-5 for more information).

## 5-5 Connecting an Explorer 443s/443sp to other instruments

Several Northstar instruments can be connected together to share data such as Depth or Speed. The Explorer 443sp uses the NMEA protocol to output data to other instruments.

### NMEA

NMEA is an industry standard for marine instrument communications. Data sent by one instrument over

an NMEA line can be read and displayed by another instrument that accepts NMEA 0183 Version 2. Depth, speed and temperature data is output by the Explorer 443sp and can be read and displayed by the Northstar Explorer R310, Explorer D210, GPS Chartplotter (500 series), or other NMEA instrument.



Explorer R310

Repeater for depth, speed, water temperature and battery voltage. Can accept many other NMEA data inputs from other instruments.



Explorer D210

Depth repeater.

Please contact your Northstar dealer for information on Northstar's full range of NMEA enabled instruments and connection options.

# Appendix A - Specifications

## Depth range

- 2 ft (0.6 m) to 600 ft (180 m).

## Display type

- FSTN greyscale.
- Screen resolution 160 high x 120 wide (pixels).
- White multi-level back lighting.

## Supply voltage

- 10 to 16.5 V DC.

## Supply current

- 280 mA min - no backlighting.
- 400 mA max - full backlighting.

## Operating temperature

- 32 to 122°F (0 to 50°C).

## Transom transducer cable length

- 26 ft (8 m) - Explorer 443sp
- 33 ft (10 m) - Explorer 443s

## Typical depth acquisition time from startup

- 2 seconds at 100 feet (30 m).

## Transmit frequency

- 200 kHz.

## Transmit power

- 150 Watts RMS @ 13.8 V DC.

## Transmit rate

- Max 20 soundings/second

## Receiver sensitivity

- Better than 10 micro volts RMS.

## Standards Compliance

- **EMC: USA** FCC Part 15 Class B.  
**Europe** (CE) IEC60945  
**New Zealand & Australia** (C Tick)  
CISPR 22
- **Environment:** IPx6 & IPx7

## Temperature measurement range

- 32 to 99.9°F (0 to 37.7°C) Resolution 0.1 units.

## Speed range

- 1 to 50 kn (57.5 mph, 96.6 kph).

## Speed resolution

- 0.0 to 9.9, 10 to 50.

## Communications

- NMEA 0183 (Ver 2.0) 4800 Baud.

## NMEA output

NMEA (0183 format) is a standard for interfacing marine electronic devices. The Northstar fishfinder can output the following data:

- DBT (Depth Below Transducer).
- DPT (Depth and Keel offset).
- TDK (Depth Northstar - proprietary).
- TKV (Speed Northstar - proprietary).
- VHW (Speed).
- MTW (Water temperature).
- XDR (Battery voltage).

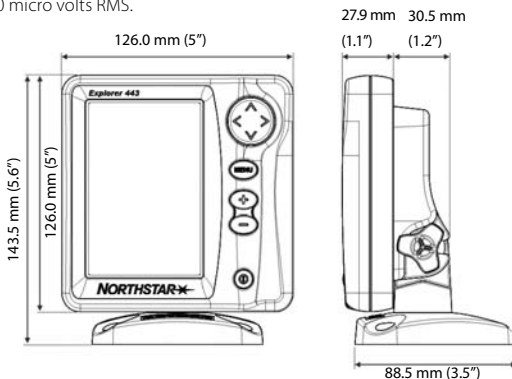

## Appendix B - Troubleshooting

This troubleshooting guide is written with the assumption that the user has read and understood the relevant sections in this manual.

It is possible in many cases to solve difficulties without having to send the display unit back to the manufacturer for repair. Please follow this trouble-shooting section before contacting the nearest Northstar dealer.

There are no user serviceable parts. Specialised methods and testing equipment are required to ensure that the display unit is reassembled correctly and is waterproof. Users who service a Northstar fishfinder themselves will void the warranty.

Repairs to the Explorer 443s/443sp may only be carried out by a service centre approved by Northstar. If the display unit must be sent into a service centre for repair, it is essential to send in the transducer(s) at the same time.

More information can be found on our Website: [www.northstarnav.com](http://www.northstarnav.com)

### 1. The fishfinder won't turn on:

- a) Northstar fishfinders are designed to operate on 12 volt battery systems, where the voltage may vary from 10 to 16.5 volts. If an excessive voltage is supplied to the unit, a resettable fuse will be tripped, turning the display unit off.
- b) Check that the power cable LT connector at the back of the display unit is securely plugged in and the collar is locked in place. The collar must be secure for watertight connection.
- c) Measure the battery voltage while the battery is under load - turn on some lights, radio, or other electrical equipment connected to the battery. If the voltage is less than 10 volts:
  - The battery terminals or wiring on the terminals may be corroded.
  - The battery may not be charging correctly or may need replacing.
- d) Inspect the power cable from end to end for damage such as cuts, breaks or squashed sections.

- e) Ensure that the red wire is connected to the positive battery terminal and the black wire to the negative battery terminal. If wired for the Auto Power option, ensure the yellow wires are connected to ignition circuit. Also check the boat's main switch circuit (see section 5-4).
- f) Check for corrosion on the power cable LT connector and clean or replace if required.
- g) Check fuses that are placed in line with the power cable. A fuse can be blown despite appearing to be good, or the fuse may be corroded. Test the fuse or replace it with a fuse known to be good.

### 2. The fishfinder won't turn off:

The fishfinder may have been wired with the Engine Hours feature enabled. In this case, the fishfinder cannot be turned off while the ignition power is on. (See Auto Power Wiring in section 5-4).

### 3. The fishfinder operates erratically:

- a) Check that the transducer does not have debris (e.g. weed, plastic bag) caught around it.
- b) The transducer may have been damaged during launching, running aground, or running underway with debris etc. If the transducer has been impacted, it may have been kicked up on the bracket. If it is not physically damaged, reset the transducer back to its original position. (See the Transducer Installation Guide for more information).
- c) When in water less than 2 feet (0.6 m) the bottom and depth readings may become inconsistent and erratic. This depth is measured from the transducer and does not allow for any keel offset setting.
- d) Manual Gain may be set too low, which may cause weak bottom echo, or no fish signals. If Auto Gain is disabled try increasing the gain.
- e) Ensure the back of the bottom surface of the transducer is slightly lower than the front and the front is as deep in the water as possible in order to minimise the generation of bubbles through cavitation. (See the Transducer Installation Guide for more information).

- f) Check the transducer and power cable LT connectors at the back of the display unit are securely plugged in and the collar is locked in place. The collar must be secure for watertight connection.
- g) Inspect the transducer and power cables from end to end for damage such as cuts, breaks or squashed sections.
- h) Ensure there is not another fishfinder or depth sounder turned on, which may interfere with the Explorer 443s/443sp.
- i) Electrical noise from the boat's engine or an accessory may be interfering with the transducer(s) and/or the Northstar fishfinder. This may cause the fishfinder to automatically decrease the gain unless using Manual Gain. The fishfinder thus eliminates weaker signals such as fish or even the bottom from the display. This may be checked by switching off other instruments, accessories (e.g. bilge pump) and the motor until the offending device is located. To stop problems from electrical noise, try:
  - Rerouting the power and transducer cable(s) away from the boat's other electrical wiring.
  - Routing the unit's power cable directly to the battery instead of through a fuse block or ignition switch.

#### **4. Bottom is not displayed:**

- a) The fishfinder may have Manual Range selected and the depth may be outside the range value selected. Either change the fishfinder to Auto Range or select another depth range (see section 3-8).
- b) The depth may be outside the fishfinder's range. While in Auto Range, the display unit will flash the last depth displayed, then display "--.-" to indicate that there is no bottom detected. A display of the bottom should reappear when it is shallower than 180 m (600 ft).

#### **5. The bottom is displayed too far up the screen:**

The fishfinder may have Manual Range selected and the selected Range value is too high for the depth. Either change the fishfinder to Auto Range or select another depth range (see section 3-8).

#### **6. Bottom echo disappears or erratic digital reading while the boat is moving:**

- a) Ensure the back of the bottom surface of the transducer is slightly lower than the front and the front is as deep in the water as possible in order to minimise the generation of bubbles through cavitation. See the Transducer Installation Guide for more information.
- b) The transducer may be in turbulent water. Air bubbles in the water disrupt the echoes returned, interfering with the fishfinder's ability to find the bottom or other targets. This often happens when the boat is reversed. The transducer must be mounted in a smooth flow of water in order for the fishfinder to work at all boat speeds.
- c) Electrical noise from the boat's motor can interfere with the fishfinder. Try some suppression spark plugs.

#### **7. If the fishfinder beeps when turned on but nothing is displayed:**

The fishfinder may be operating, but the contrast settings may have been set too high or low. Power off the fishfinder. Then hold > and press **1** to reset the fishfinder to the default contrast setting.

#### **8. The wrong language is displayed:**

(See section 2).





AMERICAS

30 Sudbury Road,  
Acton, MA 01720, USA

Ph: +1 978.897.6600

Ph: +1 800.628.4487

Fax: +1 978.897.7241

sales@bntmarine.com

EUROPE

Unit 2, Ocean Quay,  
Belvidere Rd, Southampton,

SO14 5QY, ENGLAND

Ph: +44 2380 339922

Fax: +44 2380 330345

northstaruk@northstarnav.com

AUSTRALIA

PO Box 479,  
Gladesville, NSW 2111,

AUSTRALIA

Ph: +61 2 9879 9060

Fax: +61 2 9879 9009

northstaraus@northstarnav.com

NEW ZEALAND

PO Box 68 155,  
Newton, Auckland

Auckland, NEW ZEALAND

Ph: +64 9 481 0500

Fax: +64 9 481 0590

northstarnz@northstarnav.com

[www.northstarnav.com](http://www.northstarnav.com)

**NORTHSTAR** 



Made in New Zealand  
MN000621A-G